

Determination of Aniline and Nitroanilines in Environmental and Drinking Waters by On-Line SPE

Introduction

Aniline is an organic compound widely used in the polymer, rubber, pharmaceutical, and dye industries. Aniline and its derivatives (e.g., nitroanilines) are suspected carcinogens and are highly toxic to aquatic life. Therefore, it is necessary to establish sensitive, efficient, and simple methods for the determination of aniline and its derivatives in drinking and environmental waters.

The most common techniques for the determination of aniline and its derivatives in environmental and drinking waters are gas chromatography (GC)^{1,2} and high-performance liquid chromatography (HPLC).³⁻⁵ Capillary zone electrophoresis (CZE)⁶ and spectrophotometric methods⁷ have been reported as well. Because these compounds are thermolabile and polar, a derivatization step prior to GC analysis is often required, and most of these procedures are time consuming and complicated. Therefore, HPLC analysis is a good alternative to GC analysis because derivatization is not needed.

Normally, extraction processes for aniline and its derivatives from environmental and drinking water samples prior to HPLC analysis are required due to the limited sensitivity of direct injection for these samples, which have low concentrations of anilines. The typical extraction techniques are liquid-liquid extraction⁸ and solid-phase extraction (SPE),⁹ with SPE gaining favor either in the on-line or off-line mode. Compared to off-line SPE, on-line SPE offers the advantages of full automation, absence of operator influence, time savings, and strict process control.¹⁰⁻¹²

Here, an on-line SPE HPLC system is used to fulfill the simple and sensitive determination of aniline and four nitroanilines—*o*-nitroaniline, *m*-nitroaniline, *p*-nitroaniline, and *o,p*-dinitroaniline—in tap and pond water. The analyte structures are shown in Figure 1.

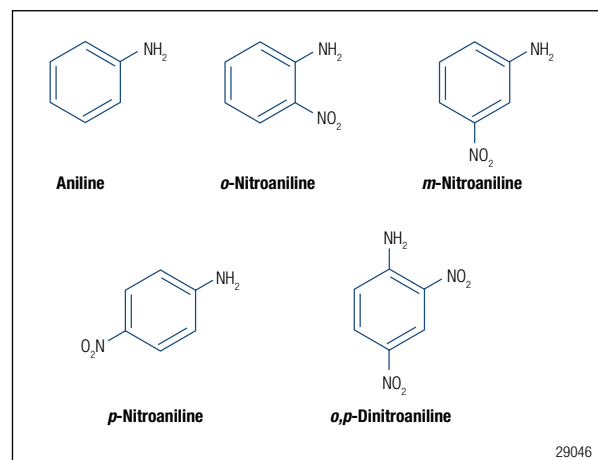

Figure 1. Structures of aniline and nitroanilines.

This on-line SPE HPLC system uses a Thermo Scientific Dionex SolEx HRP cartridge for the enrichment and a Thermo Scientific Acclaim 120 C18 column for the separation. The Thermo Scientific Dionex UltiMate 3000 Dual HPLC system provides an efficient platform to fulfill the on-line SPE and separation, and the system operates under automatic control of Thermo Scientific Dionex Chromeleon Chromatography Data System (CDS) software. The complete analysis requires only 15 min, and method detection limits (MDL) for these compounds are all less than 0.2 µg/L, which meets the requirement of United States Environmental Protection Agency (EPA) Method 8131 (GC method, MDLs range from 1.0 to 11 µg/L).¹³

Equipment

Dionex UltiMate™ 3000 HPLC system including:

DGP-3600A pump with SRD-3600 solvent rack with degasser

WPS-3000TSL semiprep autosampler with 2500 µL sample loop*

TCC-3200 thermostatted column compartment equipped with one 2p-6p valve

DAD-3000RS UV-vis detector

Dionex Chromeleon™ CDS software, Version 6.80, SR9

Thermo Scientific Orion 420A+ pH meter

*The analytical version of the WPS-3000TSL autosampler can also be converted to the semipreparative version by installing the Semipreparative Conversion Kit (P/N 6822.2450) for large-volume injections for on-line SPE.

Reagents

Deionized water, Milli-Q® Gradient A10 (EMD Millipore, Billerica, USA)

Fisher Scientific methanol (CH₃OH), HPLC grade (Cat.# AC610090040)

Fisher Scientific acetonitrile (CH₃CN), HPLC grade (Cat.#AC610010040)

Phosphoric acid (H₃PO₄), analytical grade, SCRC, China

Dipotassium hydrogen phosphate (K₂HPO₄), analytical grade, SCRC, China

Standards

Aniline, analytical standard (Fluka®, St. Louis, USA)

o-Nitroaniline, 98% (Sigma-Aldrich®, St. Louis, USA)

m-Nitroaniline, 98% (Sigma-Aldrich)

p-Nitroaniline, 99% (Sigma-Aldrich)

o,p-Dinitroaniline, 98% (Sigma-Aldrich)

Accurately weigh ~50 mg of a standard and dilute in a 50-mL volumetric flask with methanol. The concentration of the standard is 1000 mg/L (stock standard solution 1). Pipet 50 µL of stock standard 1 into a 50-mL volumetric flask and dilute to the mark with methanol. The concentration of the standard is 1000 µg/L (stock standard solution 2). Prepare four working standard solutions for the calibration with 1, 10, 50, and 100 µg/mL concentrations by adding the proper amount of stock standard solution 2 and making dilutions with methanol.

Note: The concentration of the stock standard solution 1 is not 1000 mg/L because of the < 100% purity for the standards. So, the actual volume taken for the preparation of stock standard solution 2 must be, for example, 51 µL for *o*-nitroaniline with 98% purity.

Samples

Tap water samples were collected at our Shanghai Applications Lab. Pond water samples were collected at Zhangjiang High-Tech Park located in the Pudong District of Shanghai, China.

These samples were filtered through a 0.45 µm membrane (Millex®-HN, Millipore Corporation) prior to injection.

Chromatographic Conditions

SPE Cartridge:	Dionex SolEx™ HRP Cartridge, 12–14 µm, 2.1 × 20 mm (P/N 074400) Use V-3 Holder (P/N 074403)*
Analytical Column:	Acclaim™ 120 C18, 3 µm, 4.6 × 150 mm (P/N 059133)
Mobile Phase:	For on-line SPE: A: 10 mM phosphate buffer (pH 6.5) B: CH ₃ OH In gradient (Table 1)
For Separation:	A: H ₂ O B: CH ₃ CN In gradient (Table 1)
Valve-Switching:	Table 1
Flow Rate:	2.0 and 0.5 mL/min for on-line SPE 1.0 mL/min for separation
Inj. Volume:	5000 µL on the on-line SPE cartridge*
Column Temp.:	30 °C
UV Detection:	Absorbance at 230 nm

*Two consecutive injections of 2500 µL using the User Defined Program (UDP) injection mode controlled by Dionex Chromeleon CDS software.

Time (min)	Left Pump (for On-Line SPE)			Right Pump (for Separation)			Valve Switching
	Flow Rate (mL/min)	Solvent A 10 mM Phosphate Buffer (pH 6.5) (%)	Solvent B Methanol (%)	Flow Rate (mL/min)	Solvent A H ₂ O (%)	Solvent B Acetonitrile (%)	
0	2	90	10	1.0	70	30	1–2
2		90	10		70	30	6–1
3	0.5	30	70		—	—	1–2
10		30	70		45	55	—
11	2	90	10		30	70	—
13	—	—	—		30	70	—
15	—	—	—		70	30	—

Results and Discussion

Selection of SPE Column

Considering the tolerance to large-volume injection of water samples, and the relative ease or difficulty of retention/elution of aniline and nitroanilines by SPE, two types of silica-based stationary phases (the Acclaim Mixed-Mode WCX-1 Guard and the Acclaim PA2 Guard) and two types of polymeric sorbents (the Dionex SolEx HRP Cartridge and the Thermo Scientific Dionex IonPac NG1 Guard) were evaluated as SPE columns. This evaluation followed the typical on-line SPE flow schematic shown in Figure 2. The chromatograms of aniline, *p*-nitroaniline, *m*-nitroaniline, *o*-nitroaniline, and *o,p*-dinitroaniline are shown in Figure 3.

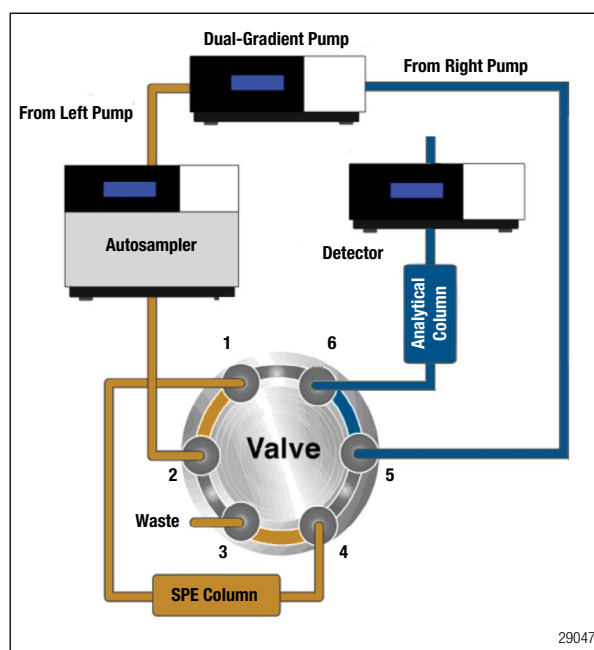

Figure 2. Flow schematic of on-line SPE.

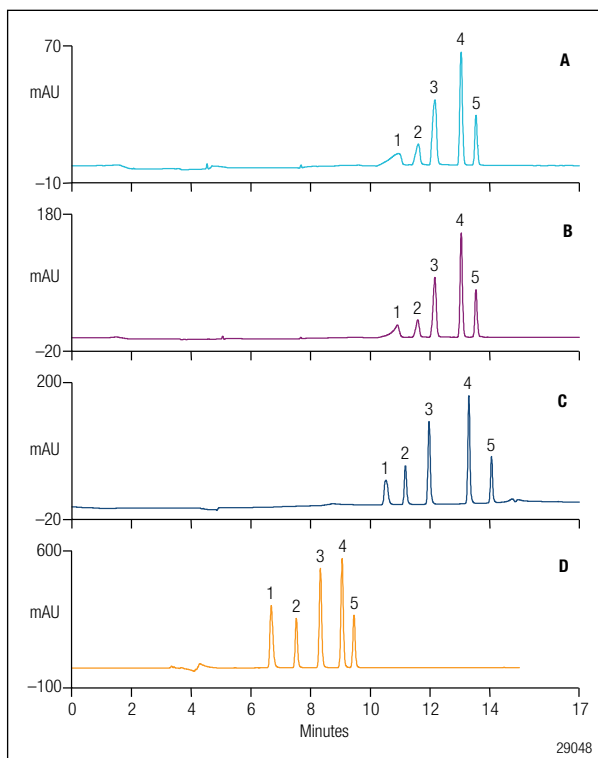

Figure 3. Chromatograms of aniline and nitroanilines (100 µg/L each) using different on-line SPE stationary phases (A) Dionex IonPac™ NG1 Guard, (B) Acclaim PA2 Guard, (C) Acclaim Mixed-Mode WCX-1 Guard, and (D) Dionex SolEx HRP Cartridge. See Table 2 for conditions.

As shown in Figure 3 A and B, severe band spreading for aniline (peak 1) was observed when using the Dionex IonPac NG1 Guard and the Acclaim PolarAdvantage II (PA2) Guard. This can be attributed to aniline's weak retention on these stationary phases, even using water as the mobile phase. During its enrichment in on-line SPE, aniline diffused on these SPE columns, resulting in severe band spreading on the analytical column even if using a reversed flush with organic mobile phase. Meanwhile, the weak retention of aniline on these stationary phases may result in its loss during the course of enrichment. Poor extraction efficiency, low to about 50%, was estimated by comparing the peak area obtained with on-line SPE to that obtained without SPE.

Although the peak shape improved using the Acclaim Mixed-Mode WCX-1 Guard (Figure 3C), a stationary phase that combines cation-exchange and RP properties, there was not a significant improvement in extraction efficiency. The Dionex SolEx HRP cartridge, packed with a divinylbenzene polymer with a hydrophilic bonded layer,¹⁴ was thus selected based on its excellent retention properties of the analytes with different polarities. As shown in Figure 3D, good peak shape of aniline was observed; and the estimated extraction efficiency was > 95%. The peak shape and efficiency of *p*-nitroaniline were also improved using the Dionex SolEx HRP cartridge.

Table 2. Chromatographic Conditions for Figure 3

On-Line SPE Stationary Phase	Dionex IonPac NG1 Guard (10 µm, 4 × 35 mm and Acclaim PA2 Guard (5 µm, 4.6 × 10 mm)		Acclaim Mixed-Mode WCX-1 Guard (5 µm, 4.6 × 10 mm) and Dionex SolEx HRP Cartridge (12–14 µm, 2.1 × 20 mm)	
Analytical Column	Acclaim 120 C18 (3 µm, 3.0 × 150 mm)		Acclaim 120 C18 (3 µm, 4.6 × 150 mm)	
Mobile Phase	For on-line SPE	50 mM NH ₄ Ac-HAc (pH 4.6)/CH ₃ OH Gradient: CH ₃ OH, 0~2 min, 1%; 6~11 min, 70%; 11~17 min, 1.0%	10 mM phosphate buffer (pH 6.5)/CH ₃ OH Gradient: CH ₃ OH, 0~3 min, 0%; 7~14.5 min, 70%; 15.1~18 min, 0%	10 mM phosphate buffer (pH 6.5)/CH ₃ OH Gradient: CH ₃ OH, 0~2 min, 10%; 3~10 min, 70%; 11~15 min, 10%
	For separation	H ₂ O/CH ₃ OH Gradient: CH ₃ OH, 0~4 min, 5%; 10~17 min, 60%	H ₂ O/CH ₃ OH Gradient: CH ₃ OH, 0 min, 10%; 2.5 min, 10%; 13~18 min, 70%; 23 min, 10%	H ₂ O/CH ₃ CN Gradient: CH ₃ CN, 0~2 min, 30%; 10 min, 55%; 11~13 min, 70%; 15 min, 30%
Flow Rate	For on-line SPE	0~2 min, 1.5 mL/min; 2.1~15 min, 0.5 mL/min; 17 min, 1.5 mL/min	0~3 min, 0.5 mL/min; 7~18 min, 1.0 mL/min; 18.1 min, 0.5 mL/min	0~2 min, 2.0 mL/min; 3~10 min, 0.5 mL/min; 11~15 min, 2 mL/min
	For separation	0.5 mL/min	1.0 mL/min	
Inj. Volume	5000 µL on the on-line SPE cartridge (two consecutive injections of 2500 µL using UDP injection mode)			
Column Temp.	30 °C		30 °C	
UV Detection	285 nm		230 nm	
Sample	Tap water spiked with anilines standards (100 µg/L each)			
Peaks	1) Aniline, 2) <i>p</i> -nitroaniline, 3) <i>m</i> -nitroaniline, 4) <i>o</i> -nitroaniline, 5) <i>o,p</i> -dinitroaniline			

Effect of Mobile Phase for On-Line SPE

The effect of mobile phase on on-line SPE was investigated. As shown in Figure 4, when using either water or phosphate buffer mobile phase containing 10% methanol for sample enrichment on the Dionex SolEx HRP cartridge, no difference was observed for the *p*-nitroaniline, *m*-nitroaniline, *o*-nitroaniline, and *o,p*-dinitroaniline peaks on the Acclaim 120 C18 analytical column. A tailing aniline peak was observed when using water; however, the peak became sharp and symmetrical when using phosphate buffer. So, a 10-mM phosphate buffer (pH 6.5) mobile phase was used for on-line SPE.

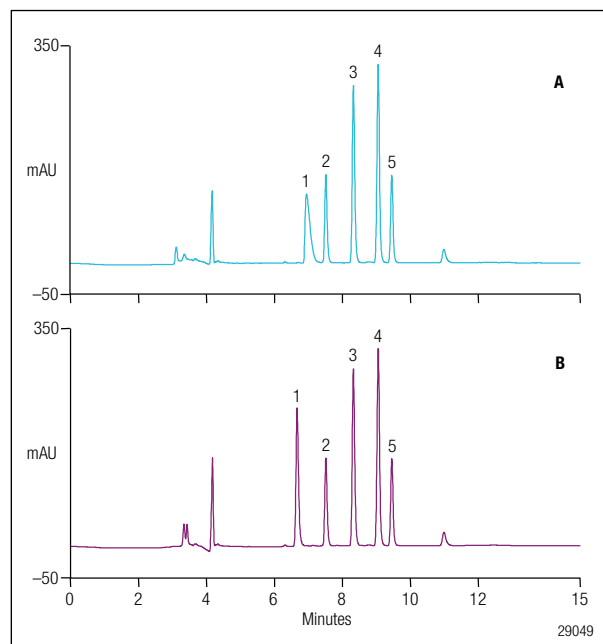

Figure 4. Chromatograms of aniline, *p*-nitroaniline, *m*-nitroaniline, *o*-nitroaniline, and *o,p*-dinitroaniline using (A) H₂O/CH₃OH and (B) 10 mM phosphate buffer (pH 6.5)/CH₃OH mobile phases for on-line SPE. See Table 3 for conditions.

Table 3. Chromatographic Conditions for Figure 4

On-Line SPE Cartridge	Dionex SolEx HRP		
Analytical Column	Acclaim 120 C18		
Mobile Phase	For on-line SPE	H ₂ O/CH ₃ CN Gradient: CH ₃ CN, 0~2 min, 10%; 3~10 min, 70%; 11~15 min, 10%	10 mM phosphate buffer (pH 6.5)/CH ₃ OH Gradient: CH ₃ OH, 0~2 min, 10%; 3~10 min, 70%; 11~15 min, 10%
	For separation	H ₂ O/CH ₃ CN Gradient: CH ₃ CN, 0~2 min, 30%; 10 min, 55%; 11~13 min, 70%; 15 min, 30%	
Flow Rate	For on-line SPE	0~2 min, 2.0 mL/min; 3~10 min, 0.5 mL/min; 11~15 min, 2 mL/min	
	For separation	1.0 mL/min	
Inj. Volume	5000 μL on the on-line SPE cartridge (two consecutive injections of 2500 μL using UDP injection mode)		
Column Temp.	30 °C		
UV Detection	230 nm		
Sample	Tap water spiked with aniline standards (100 μg/L for each)		
Peaks	1) Aniline, 2) <i>p</i> -nitroaniline, 3) <i>m</i> -nitroaniline, 4) <i>o</i> -nitroaniline, 5) <i>o,p</i> -dinitroaniline		

Method Reproducibility, Linearity, and Detection Limits

Method reproducibility was estimated by making five consecutive 5000-μL injections of mixed standards with a 10 μg/L concentration of each. Retention time and peak area reproducibilities are summarized in Table 4 and show good precision.

Table 4. Reproducibility for Peak Retention Time and Area

Analyte	Retention Time RSD	Peak Area RSD	Concentration of Standard (μg/L)
Aniline	0.022	0.300	10
<i>p</i> -Nitroaniline	0.031	0.183	
<i>m</i> -Nitroaniline	0.028	0.051	
<i>o</i> -Nitroaniline	0.026	0.123	
<i>o,p</i> -Dinitroaniline	0.039	0.160	

Table 5. Method Linearity Data and Method Detection Limits (MDL)

Analyte	Regression Equation	r	Range of Standards (µg/L)	MDL, µg/L	
				Current Data	Data Reported in EPA Method 8131
Aniline	$A = 0.3686 c - 0.1530$	0.9999	1–100	0.2	2.3
<i>p</i> -Nitroaniline	$A = 0.2290 c - 0.0830$	1.0000		0.2	1.0
<i>m</i> -Nitroaniline	$A = 0.4770 c + 0.0302$	1.0000		0.1	3.3
<i>o</i> -Nitroaniline	$A = 0.5286 c - 0.0194$	1.0000		0.1	11.0
<i>o,p</i> -Dinitroaniline	$A = 0.2432 c - 0.0252$	1.0000		0.2	8.9

Calibration linearity for aniline and nitroanilines was investigated by making three consecutive injections of a mixed standard prepared at four different concentrations. The external standard method was used to establish the calibration curve and to quantify these compounds in samples. Excellent linearity was observed from 1 to 100 µg/L when plotting concentration versus peak area, and the correlation coefficient was ≥ 0.9999 for each plot. The MDLs of each compound for UV detection were calculated using $S/N = 3$ (signal to noise), and all were ≤ 0.2 µg/L. Table 5 summarizes the method linearity and MDL data, which show excellent method linearity and sensitivity, with detection limits well below those defined in the EPA method.¹³

Sample Analysis

Chromatograms of tap and pond water samples, as well as the same samples spiked with aniline and related standards (1.0 µg/L each and 10 µg/L each, respectively), are shown in Figures 5 and 6, and the related data are summarized in Table 6. Recoveries for each standard in both sample sets ranged from 98–108% for the 10 µg/L standard spiked samples, and ranged from 93–147% for the 1 µg/L standard spiked samples. None of the samples had detectable aniline or nitroanilines.

The real samples may sometimes yield a false positive for aniline and/or one of the nitroanilines. An efficient and convenient way to determine if the peak is a target analyte is to compare the peak's UV spectrum to that of standards. Therefore, using a photodiode array detector for this analysis will help reduce the possibility of false positives.

When the pond water sample was analyzed, a small peak with retention time near that of aniline was found and labeled as aniline with a concentration 0.3 µg/L, similar to the estimated MDL of aniline (0.2 µg/L). Comparison of the UV spectra shown in Figure 7 revealed that the peak was not aniline. The spike-recovery of aniline at 1.0 µg/L level in pond water, 147%, also suggests that there is interference.

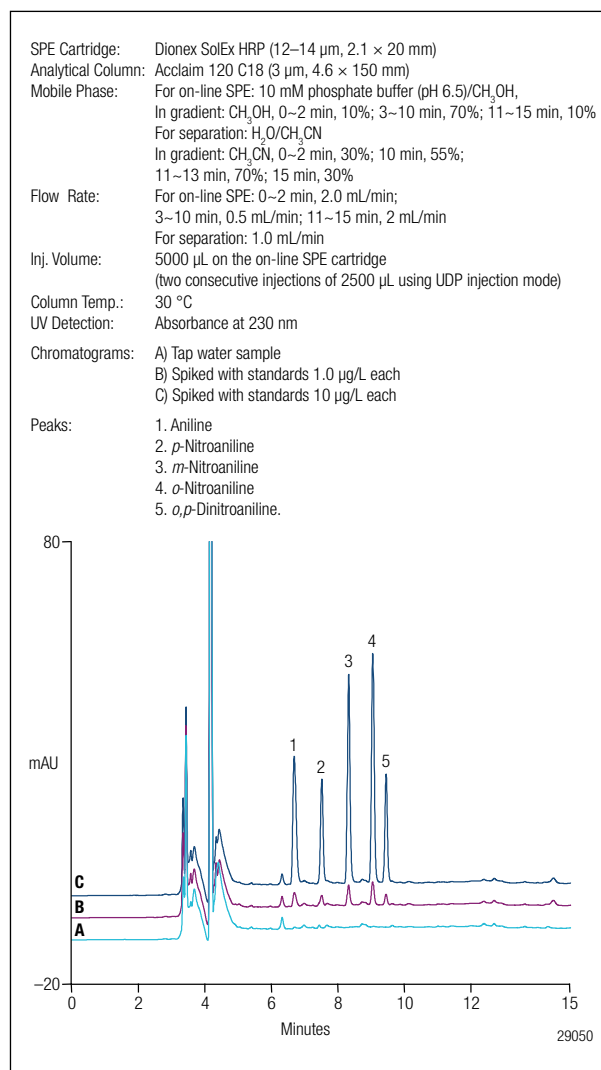

Figure 5. Chromatograms of (A) tap water sample, (B) the same sample spiked with 1.0 µg/L aniline and nitroanilines standard, and (C) spiked with 10 µg/L.

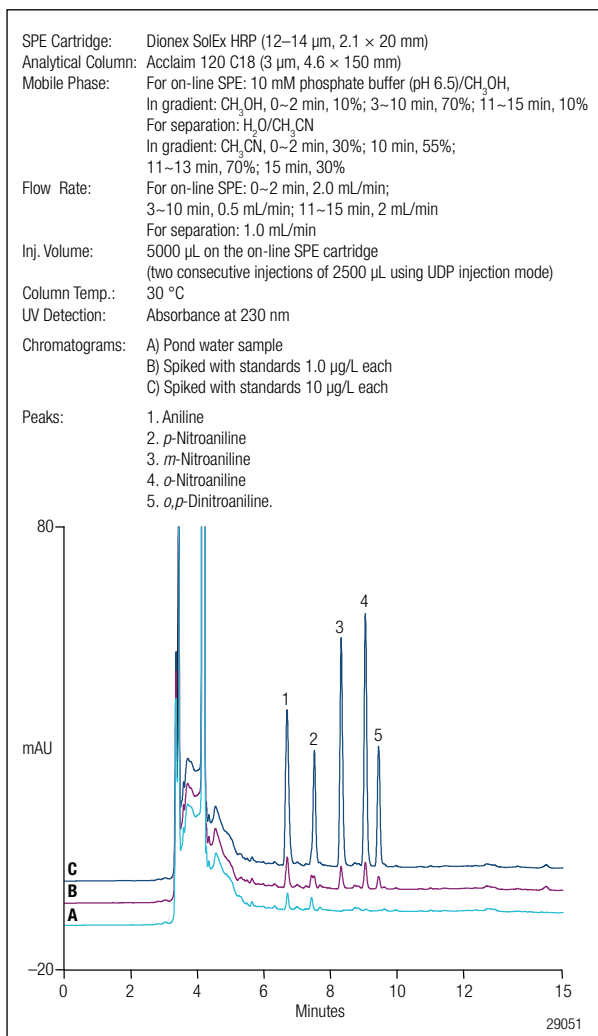

Figure 6. Chromatograms of (A) pond water sample, (B) the same sample spiked with 1.0 $\mu\text{g/L}$ aniline and nitroanilines standard, and (C) spiked with 10 $\mu\text{g/L}$.

In addition, as shown in Figures 5 and 6, interference with retention time near that of *p*-nitroaniline (peak 2) was found. Although it was not labeled as *p*-nitroaniline, its presence affects the spike-recoveries of *p*-nitroaniline at the 1.0 $\mu\text{g/L}$ level in both pond and tap waters samples (140% and 127%, respectively). This demonstrates that the limits of detection are often set by matrix interference instead of instrumental uncertainties in the analysis of environmental samples.

Table 6. Analysis Results of Anilines in Water Samples

Sample	Pond Water				
Analyte	Detected ($\mu\text{g/L}$)	Added ($\mu\text{g/L}$)	Recovery (%)	Added ($\mu\text{g/L}$)	Recovery (%)
Aniline	ND	1.0	147	10	104
<i>p</i> -Nitroaniline	ND		140		101
<i>m</i> -Nitroaniline	ND		94.2		99.7
<i>o</i> -Nitroaniline	ND		105		101
<i>o,p</i> -Dinitroaniline	ND		101		98.8
Sample	Tap Water				
Analyte	Detected ($\mu\text{g/L}$)	Added ($\mu\text{g/L}$)	Recovery (%)	Added ($\mu\text{g/L}$)	Recovery (%)
Aniline	ND	1.0	103	10	100
<i>p</i> -Nitroaniline	ND		127		108
<i>m</i> -Nitroaniline	ND		93.1		100
<i>o</i> -Nitroaniline	ND		109		102
<i>o,p</i> -Dinitroaniline	ND		103		100

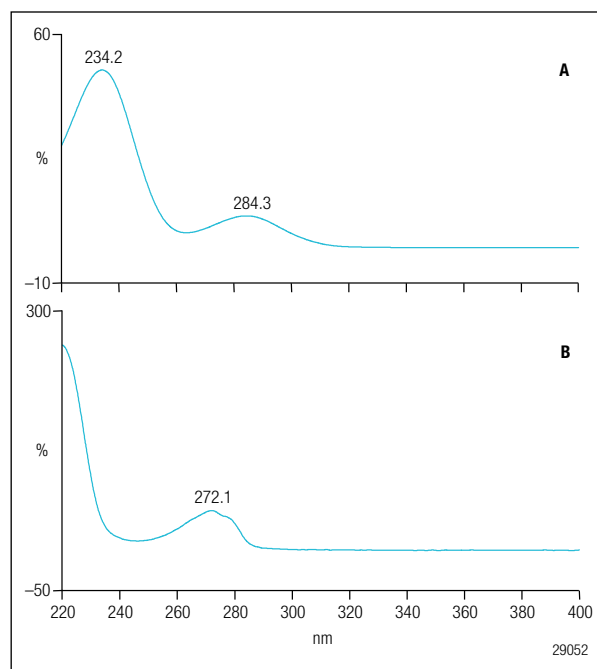

Figure 7. UV spectra of (A) aniline standard and (B) the putative aniline peak in a pond water sample.

Conclusion

This work describes an on-line SPE system using the Dionex SolEx HRP cartridge to enrich aniline and nitroanilines followed by HPLC with UV detection. The enrichment of aniline and nitroanilines in tap and pond water is sufficient, and baseline separation on the Acclaim 120 C18 column is achieved. The Dionex UltiMate 3000 Dual HPLC system provides an efficient platform to fulfill this on-line SPE, and the system

operates under automatic control of Dionex Chromeleon CDS software. The determination of aniline and nitroanilines in tap and pond water is simple, rapid, and sensitive, and meets the MDL requirement of the EPA Method 8131. Although this work cannot be a substitute for the EPA method, it does demonstrate that these analytes can be determined by on-line SPE-HPLC while meeting the performance criteria of the EPA method.

References

- Brede, C.; Skjevraak, I.; Herikstad, H. Determination of Primary Aromatic Amines in Water Food Simulant Using Solid-Phase Analytical Derivatization Followed by Gas Chromatography Coupled with Mass Spectrometry *J. Chromatogr., A* **2003**, *983*, 35.
- Chiang, J. S.; Huang, S. D. Simultaneous Derivatization and Extraction of Anilines in Waste Water with Dispersive Liquid-Liquid Microextraction Followed by Gas Chromatography-Mass Spectrometric Detection *Talanta* **2008**, *75*, 70.
- Jen, J. F.; Chang, C. T.; Yang, T. C. On-Line Microdialysis-High-Performance Liquid Chromatographic Determination of Aniline and 2-Chloroaniline in Polymer Industrial Wastewater *J. Chromatogr., A* **2001**, *930*, 119.
- Sarafraz-Yazdi, A.; Es'haghi, Z. Liquid-Liquid-Liquid Phase Microextraction of Aromatic Amines in Water Using Crown Ethers by High-Performance Liquid Chromatography with Monolithic Column *Talanta* **2005**, *66*, 664.
- Zhao, L. M.; Zhu, L. Y.; Lee, H. K. Analysis of Aromatic Amines in Water Samples by Liquid-Liquid-Liquid Microextraction with Hollow Fibers and High-Performance Liquid Chromatography *J. Chromatogr., A* **2002**, *963*, 239.
- Li, J.; Yuan, Z. B. Separation of Aniline Derivatives by Micellar Electrokinetic Capillary Chromatography *Chin. Chem. Lett.* **2004**, *15*, 947.
- Gu, X. X.; Li, C. Y.; Qi, X.; Zhou, T. Z. Determination of Trace Aniline in Water by a Spectrophotometric Method After Preconcentration on an Organic Solvent-Soluble Membrane Filter *Anal. Lett.* **1997**, *30*, 259.
- Wu, X. H.; Lei, Z. G.; Li, Q. S.; Zhu J. Q.; Chen, B. H. Liquid-Liquid Extraction of Low-Concentration Aniline from Aqueous Solutions with Salts *Ind. Eng. Chem. Res.* **2010**, *49*, 2581.
- Patsias, J.; Papadopoulou-Mourkidou, E. Development of an Automated On-Line Solid-Phase Extraction-High Performance Liquid Chromatographic Method for the Analysis of Aniline, Phenol, Caffeine and Various Selected Substituted Aniline and Phenol Compounds in Aqueous Matrices *J. Chromatogr., A* **2000**, *904*, 171.
- Thermo Fisher Scientific. *Determination of Phenols in Drinking and Bottled Mineral Waters Using Online Solid-Phase Extraction Followed by HPLC with UV Detection*. Application Note 191, LPN 1949, 2007, Sunnyvale, CA.
- Thermo Fisher Scientific. *Determination of Polycyclic Aromatic Hydrocarbons (PAHs) in Edible Oils by Donor-Acceptor Complex Chromatography (DACC)-HPLC with Fluorescence Detection*. Application Note 196, LPN 1998, 2008, Sunnyvale, CA.
- Thermo Fisher Scientific. *Determination of Polycyclic Aromatic Hydrocarbons (PAHs) in Tap Water Using On-Line Solid-Phase Extraction Followed by HPLC with UV and Fluorescence Detections*. Application Note 213, LPN 2126, 2009, Sunnyvale, CA.
- Aniline and Selected Derivatives by Gas Chromatography*; U.S. EPA Method 8131, U.S. Environmental Protection Agency: Cincinnati, OH, 1996.
- Thermo Fisher Scientific. *SolEx HRP On-Line Sample SPE Concentration Cartridges*. LPN 2565, 2010, Sunnyvale, CA.

www.thermoscientific.com/dionex

©2016 Thermo Fisher Scientific Inc. Milli-Q and Millex are registered trademarks of EMD Millipore. Fluka and Sigma-Aldrich are registered trademarks of Sigma-Aldrich Co. LLC. All other trademarks are the property of Thermo Fisher Scientific Inc. and its subsidiaries. This information is presented as an example of the capabilities of Thermo Fisher Scientific Inc. products. It is not intended to encourage use of these products in any manners that might infringe the intellectual property rights of others. Specifications, terms and pricing are subject to change. Not all products are available in all countries. Please consult your local sales representative for details.

Australia +61 3 9757 4486
Austria +43 1 616 51 25
Benelux +31 20 683 9768
 +32 3 353 42 94
Brazil +55 11 3731 5140

China +852 2428 3282
Denmark +45 36 36 90 90
France +33 1 39 30 01 10
Germany +49 6126 991 0
India +91 22 2764 2735

Ireland +353 1 644 0064
Italy +39 02 51 62 1267
Japan +81 6 6885 1213
Korea +82 2 3420 8600
Singapore +65 6289 1190
Sweden +46 8 473 3380

Switzerland +41 62 205 9966
Taiwan +886 2 8751 6655
UK +44 1276 691722
USA and Canada +847 295 7500

Thermo
 S C I E N T I F I C

Part of Thermo Fisher Scientific